

MC 精密アングルプレート OSM-173C MC PRECISION ANGLE PLATE OSM-173C

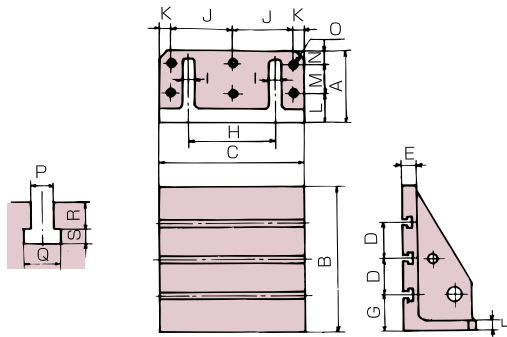
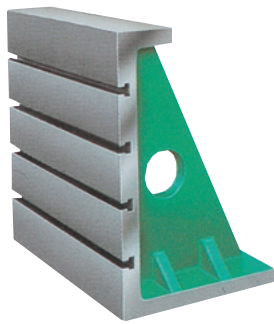

- ★材 質 …… FC300
- ★熱処理 …… 焼鈍
- ★仕 上 …… 機械仕上、研削仕上
- ★Material …… FC300
- ★Heat treatment …… Annealed
- ★Finish …… Machine finish
Ground finish

●OSM-173C 精度・寸法表 Accuracy & dimensions OSM-173C

No.	寸 法 Size (mm)														T溝寸法 T-slot size (mm)				T溝本数 Number of T-slots	仕上 Finish	直角度 Squareness (±) (mm)	製品質量 約 Weight Approx. (kg)
	A(巾)×B(高)×C(長) Width×Height×Length	D	E	F	G	H	I	J	K	L	M	N	O	P	Q	R	S					
1	200 × 400 × 360	100	60	30	50	240	30	160	20	80	80	40	M16用 掘付穴 Mounting hole for M16	18	30	22	12	4	研削 Grinding	0.03	50	
2	250 × 500 × 500	100	60	30	100	300	40	200	50	100	100	50	M16用 掘付穴 Mounting hole for M16	18	30	22	12	4	研削 Grinding	0.03	156	
3	300 × 600 × 600	150	60	40	150	400	40	250	50	125	125	50	M16用 掘付穴 Mounting hole for M16	18	30	22	12	3	研削 Grinding	0.03	219	
4	400 × 800 × 800	150	60	50	100	500	50	320	80	160	165	75	M16用 掘付穴 Mounting hole for M16	18	30	22	12	5	機械 Machine	0.10	526	

※御希望により上記以外の寸法も製作致します。 Special sizes not mentioned above can be produced at your request.

MC 精密大型アングルプレート OSM-373B MC LARGE ANGLE PLATE OSM-373B

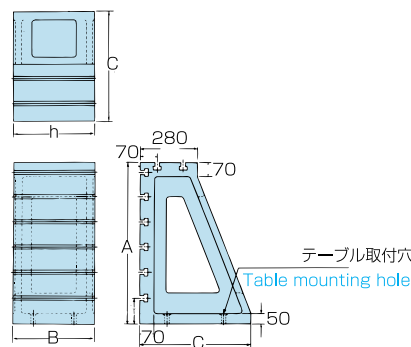

●T溝付の為、ワークのセットが簡単に行えるのが特長で、MC機械から大型機械迄、使用用途は広範囲です。

- ★材 質 …… FC300
- ★熱処理 …… 焼鈍
- ★仕 上 …… 機械仕上

●Main feature of this plate is easy set-up of workpiece because of T-slot, also to be used wide range machines from MC machines to bigger machines.

- ★Material …… FC300
- ★Heat treatment …… Annealed
- ★Finish …… Machine finish

●OSM-373B 精度・寸法表 Accuracy & dimensions OSM-373B

No.	T 溝 T-slot (mm)	T溝数 Number of T-slots	T溝ピッチ T-slot pitch (mm)	寸 法 Size (mm)				直角度 Squareness (±)	仕上 Finish	製品質量 Weight (kg)
				A	B	C	T			
1	18 H8	8	125	800	400	550	125	0.05	機 械 Machine	約 Approx. 373
2	22 H8	7	150							365
3	24 H8	7	150							344
4	18 H8	9	125	1000	500	550	150	0.05	機 械 Machine	481
5	22 H8	8	150							473
6	24 H8	8	150							439

※御希望により上記以外の寸法も製作致します。 Special sizes not mentioned above can be produced at your request.